

I:\proj\FRAME_Spec\PIRNE_STANDARD_Elec\T\0481051\CADD\GenASchematic.DWG - Scale:1:1 Date:01/21/2008 Time:1:4:44 Layout: ECOLLUTION_CONTROL

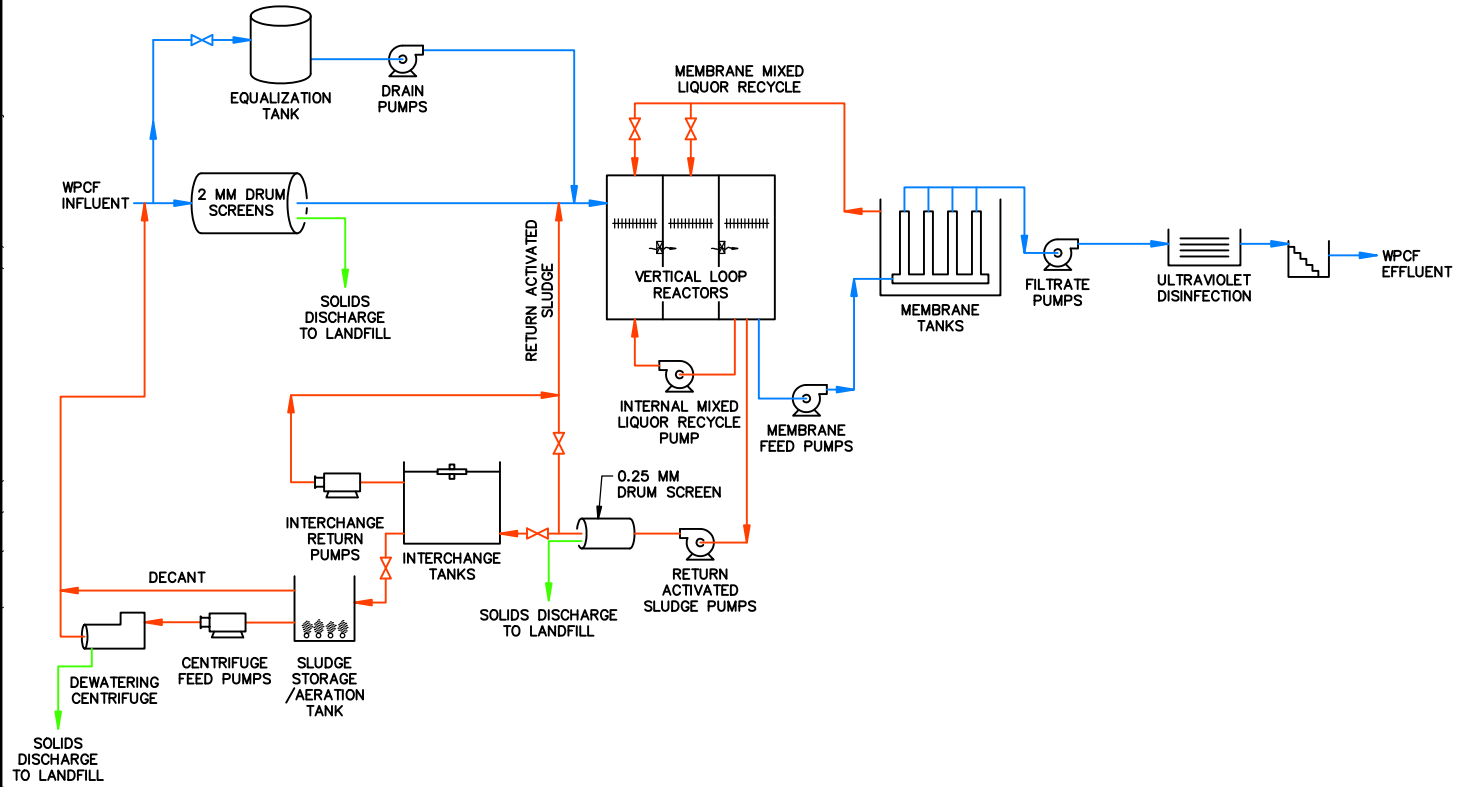

WPCF Influent-The wastewater comes to the plant from the Pierce Avenue pump station. A key point in controlling the impacts of Combined Sewer Overflows the lift station will redirect flow from separated sewer systems in the north and west parts of the City to the new plant. Eventually growth in the bypass area will discharge to the plant directly.

2MM Drum Screens-Large Drums of woven wire with 2mm openings will separate large solids from the incoming wastewater. These compact drum screens will replace the usual primary clarifiers.

Equalization Tanks-To minimize tank sizing and provide a consistent flow, high flows over 2 MGD will divert to a flow equalization basin and be fed back into the plant at a slower rate.

Vertical Loop Reactors-This is a biological process where bacteria removes organic materials from the wastewater. By regulating the amount of oxygen provided to the bacteria, we can develop bacterial communities that treat organic carbon waste, nitrogen, ammonia, and phosphorus to meet our NPDES permit limits.

Membrane Bioreactor-Combining the roles of traditional clarifiers, filters, and sludge thickeners; the membrane bioreactor separates the clean water from the biological mixed liquor. A pump provides suction on a thin membrane to pull the water through small pores leaving behind the solids and microorganisms.

Ultraviolet Disinfection-The clean water from the membrane bioreactor passes through a disinfection unit to kill any remaining bacteria. Ultraviolet light at a wavelength of 250-270 nm passes through the water to destroy the bacteria cells.

Post Aeration-To insure that the plant discharge does not deplete the oxygen in the Hocking River, the effluent passes through an aeration chamber to add oxygen to the water to our permit limit of 6 mg/l or higher.

0.25 Drum Screen-Mixed liquor from the Vertical Loop Reactors and the Membrane Bioreactor pass through a drum screen to remove inert materials before returning to the treatment process.

Sludge Interchange Tanks-Excess mixed liquor will be sent to an interchange tank. By regulating the amount of air, bacteria begins to breakdown to provide nutrients for the bacteria in the Vertical Loop Reactors. The interchange tanks replace traditional digestors and reduce the amount of sludge that must be disposed.