

ELEVATION

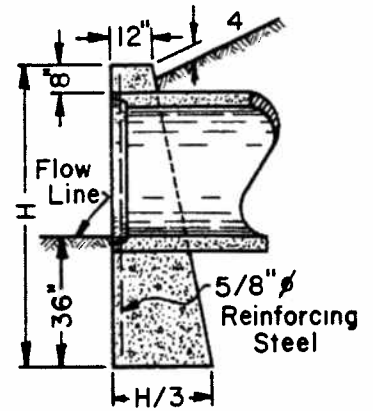

SECTION A-A

NOTES:

NO. 1 HEADWALL WHERE REQUIRED WILL BE PROVIDED FOR NONSKEWED CULVERTS HAVING A DIAMETER OR RISE OF 36" OR LESS.

CONCRETE SHALL BE CLASS "C".
REINFORCING STEEL BARS SHALL BE 5/8 INCH ROUND.

DIMENSIONS AND QUANTITIES ARE SHOWN FOR CIRCULAR SECTIONS ONLY. IT WILL BE NECESSARY TO DETERMINE DIMENSIONS FOR THE NO. 1 HEADWALL REQUIRED FOR REINFORCED ELLIPTICAL CONCRETE PIPE OR CORRUGATED METAL PIPE ARCHES IN ACCORDANCE WITH THE EQUATIONS LISTED ON THIS DRAWING.

CHAMFER ALL EXPOSED CORNERS 3/4 OF AN INCH.
FOUNDATION. WHERE THE SOIL BORINGS INDICATE A BEARING CAPACITY OF LESS THAN 2600 POUNDS PER SQUARE FOOT, IT WILL BE NECESSARY TO INCREASE THE WIDTH OF THE BASE.

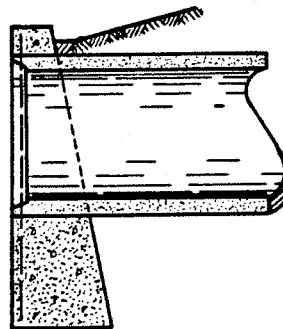

INLET END
GROOVE OR BELL
UPSTREAM

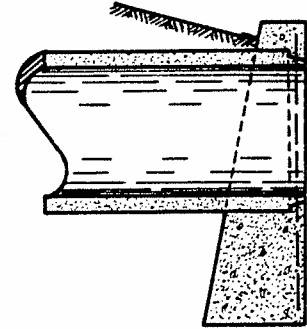

OUTLET END
TONGUE OR SPIGOT
DOWNSTREAM

RIGID PIPE

DIMENSIONS			QUANTITIES ONE HEADWALL	
DIAMETER	H	L	CONCRETE CU. YDS.	REINFORCING STEEL LBS.
15"	5'-2"	7'-0"	1.7	41
18"	5'-5"	8'-4"	2.2	57
21"	5'-8"	9'-8"	2.8	62
24"	5'-11"	11'-0"	3.3	69
30"	6'-5"	13'-8"	4.7	92
36"	7'-0"	16'-4"	6.5	105

L CIRCULAR SECTIONS = $5D + 4T$
 L ELLIPTICAL OR PIPE~ARCH = $4R + 4T + S$
 H CIRCULAR SECTIONS = $D + T + 44"$
 H ELLIPTICAL OR PIPE~ARCH = $R + T + 44"$
 D = DIAMETER OF PIPE
 R = RISE OF PIPE
 S = SPAN OF PIPE
 T = THICKNESS OF BARREL
 L = LENGTH OF HEADWALL
 H = HEIGHT OF HEADWALL

APPROVED 7/28/87
DATE

S. Kent Huston
CITY ENGINEER

REVISED:

STANDARD
HEADWALL

NO. 1

(O.D.O.T. HW-1)

CITY OF LANCASTER, OHIO
DEPARTMENT OF ENGINEERING

STANDARD
CONSTRUCTION DRAWING

DWG. BY: SLH
CHK'D BY: RM
FILE NUMBER
D-5